



Tuning Fork Crystal

SMD-version

part no.	12.87166
model	KX-327RF
frequency	32.768 kHz
operating temperature	-40° ~ +125°C
frequency tolerance (df/F) at +25°C ±3°C	±20 ppm
temperature tolerance (parabolic coefficient) max.	-0.04 ppm/°C ²
turnover temperature	+25°C ±5°C
storage temperature range	-55°C ~ +125°C
load capacitance C _L	12.5 pF
motional capacitance(C ₁) typ.	0.005 pF
series resonance R1	80k Ohm typ., 120k Ohm max.
aging (df/F) (first year) at 25°C ±3°C max.	±3 ppm
shunt capacitance C ₀	1.3 pF typ.
drive level max.	0.5 μW
contents of reel	3000 pcs.

Dimensions (mm):

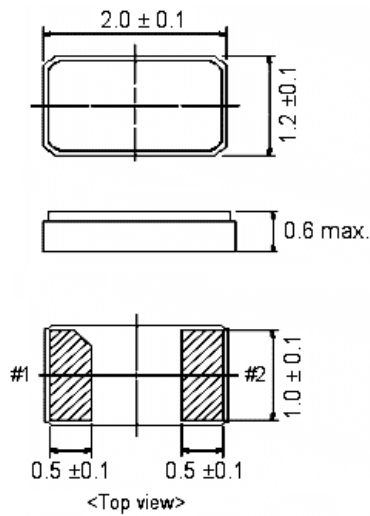

Suggested soldering pad:

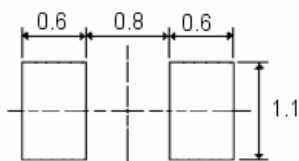

Reflow soldering condition:

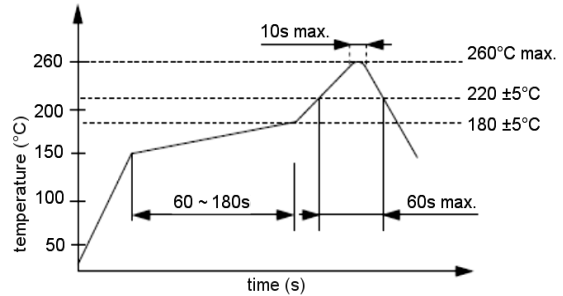

Tape specification:

