

Specifications

Parameters	Product	Option Codes
	GSX-758	
Frequency range: 50.0 ~ 315MHz	<input checked="" type="checkbox"/>	
Calibration tolerance: ±20ppm ±50ppm Other values (±20ppm ~ ±100ppm)	<input checked="" type="checkbox"/> <input type="checkbox"/> <input type="checkbox"/>	2 5 specify
Temperature stability: ±20ppm ±50ppm Other values (±20ppm ~ ±100ppm)	<input checked="" type="checkbox"/> <input type="checkbox"/> <input type="checkbox"/>	2 5 specify
Operating temperature range: -20 to +70°C -40 to +85°C Other values	<input checked="" type="checkbox"/> <input type="checkbox"/> <input type="checkbox"/>	2 4 specify
Circuit condition: 16pF 18pF 20pF 30pF Other values	<input checked="" type="checkbox"/> <input type="checkbox"/> <input type="checkbox"/> <input type="checkbox"/> <input type="checkbox"/>	D E F J specify
Oscillation mode: Fundamental	<input checked="" type="checkbox"/>	F
Static capacitance (C₀): 7pF max	<input checked="" type="checkbox"/>	
Equivalent series resistance: 30Ω max	<input checked="" type="checkbox"/>	
Ageing: ±5ppm max first year	<input checked="" type="checkbox"/>	
Test drive level: 100μW	<input checked="" type="checkbox"/>	

Standard. Optional - Please specify required code(s) when ordering

Ordering Information

Product name + option codes + frequency

eg: **GSX-758/221DF 155.52MHz** 20/20/10/16-F (standard)

GSX-758/552JF 77.760MHz 50/50/20/30-F

Option code X (eg GSX-758/X) denotes a custom specification.

Features

- ▶ **Fundamental mode up to 315MHz**
- ▶ **Plasma etched inverted mesa process**
- ▶ **Wide pulling range (fundamental mode)**
- ▶ **Small & medium volumes also available**
- ▶ **Custom frequencies available on short leadtimes**

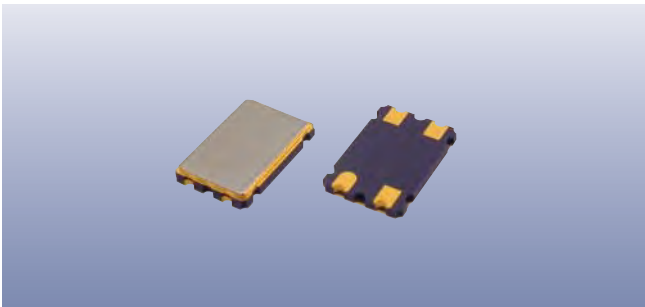

Construction

- ▮ Ceramic body with gold-plated pads
- ▮ Metal lid, seam sealed

Composition



This product is lead-free, and is fully compliant with the RoHS 2 directive 2011/65/EC



Packaging & Handling

Production quantities supplied on T&R, 1k or 3k pcs per reel. Small quantities may be supplied on tape (no reel), or in bulk.

Marking

FREQUENCY DC
PARTNO

Marking type: Laser
DC = Date code in YM, eg "EB" = Feb 2015

	A	B	C	D	E	F	G	H	J	K	L	M
Y	1	2	3	4	5	6	7	8	9	0		
M	Jan	Feb	Mar	Apr	May	Jun	Jul	Aug	Sep	Oct	Nov	Dec

Tape & Reel Specification

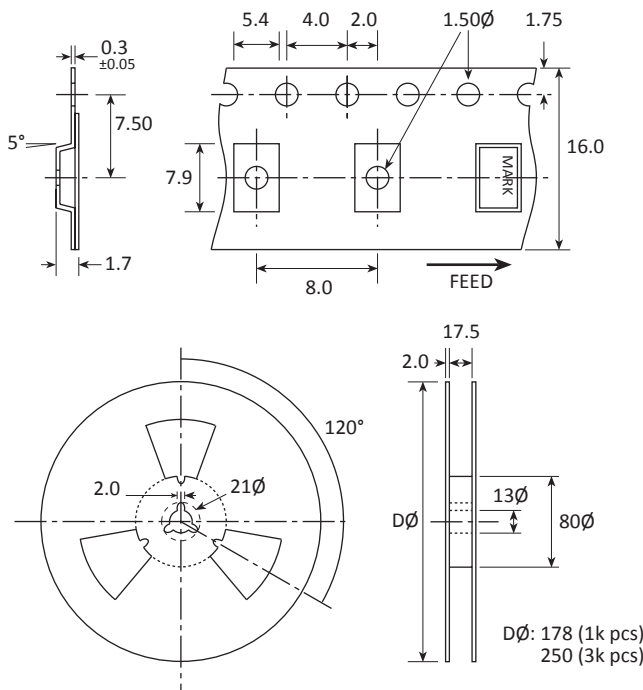

Not to scale. Dimensional tolerances ±0.1mm unless otherwise stated.

Soldering Profile

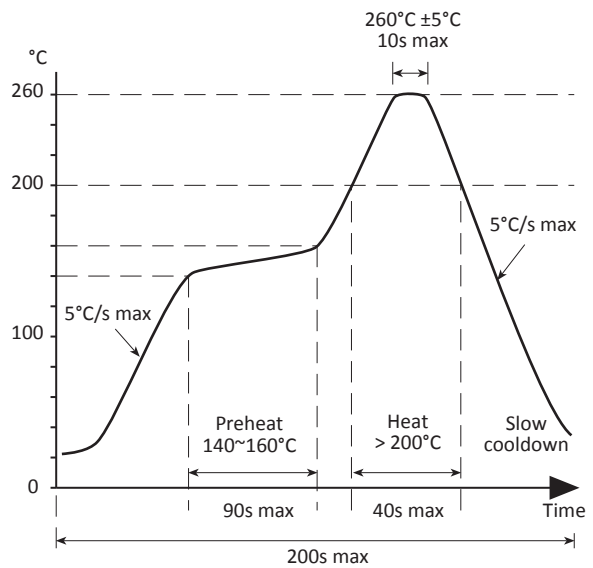

Maximum solder resistance: 260°C x 10 secs x 2.