

MSH Series 3.2 x 2.5 Ceramic SMD Oscillator

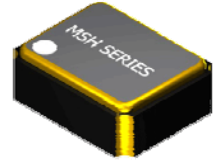

- Low Profile Ceramic SMD Package
- Hermetically Sealed
- Tristate Function/Standby Option
- Wide Frequency Range



Frequency Range	1.544MHZ to 70.000MHZ	1.544MHZ to 110.000MHZ	
Temperature Stability*	(See Part Number Guide for Options)		
Aging (+25°C ±3°C)	±5ppm First Year		
Operating Temperature Range	(See Part Number Guide for Options)		
Storage Temperature Range	-55°C to +125°C		
Supply Voltage (±10%)	+1.80VDC	+2.50VDC	+3.30VDC
Supply Current	1.544MHZ to 9.999MHZ	10mA max	12mA max
	10.000MHZ to 35.999MHZ	12mA max	14mA max
	36.000MHZ to 49.999MHZ	15mA max	20mA max
	50.000MHZ to 110.000MHZ	25mA max	30mA max
Standby Current (With Stand-by Option)	100µA		
Tristate	VOH = 70% of Vdd min or No Connection to Enable Output VOL = 30% of Vdd max or grounded to Disable Output (High Impedence)		
Logic "0"	10% Vdd max		
Logic "1"	90% Vdd min		
Output Type	HCMOS		
Symmetry (50% of waveform)	(See Part Number Guide for Options)		
Rise/Fall Time (10% to 90% of Supply Voltage)	5nSEC	6nSEC	7nSEC
Load	15pF		
Start-up Time	2mSec max		

* Inclusive of Temperature., Load and Voltage.

Mechanical & Environmental Detail

Humidity	85% RH, 85°C, 48 Hours
Hermetic Seal	Leak Rate 5×10^{-8} ATM cc/s He
Solderability	MIL-STD-202G, Method 208
Reflow Solderability	260°C for 10 seconds
Vibration	MIL-STD-202G, Method 204 35G, 50 to 2000 Hz
Shock	MIL-STD-202G, Method 203 Test Cond E, 1000G's, ½ Sinewave
MIL-STD-883	Available with Level B Screening

Marking Detail

First Line = MXX.XX (not to exceed 5 characters)		
M	=	MMD
XX.XX	=	Device Frequency (four digits including decimal point)
Second Line = SYWWL (not to exceed 5 characters)		
S	=	Internal Code
YWW	=	Date Code (Year/Week)
L	=	RoHS Compliant

**QUALITY SYSTEM
CERTIFIED
= ISO 9001 =**



Part Number Guide

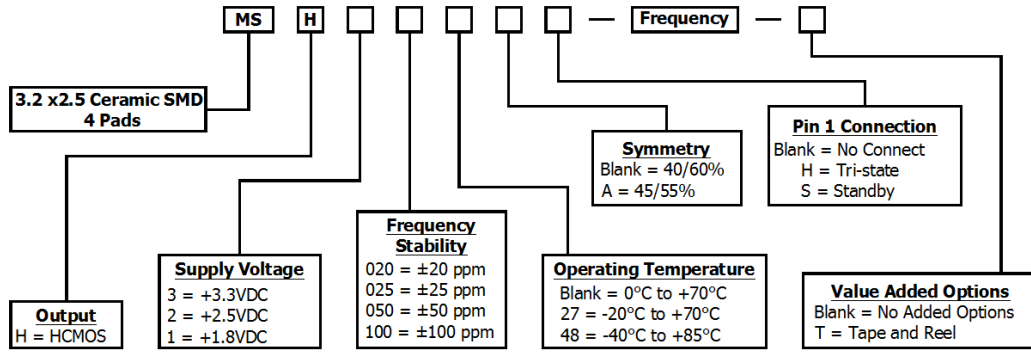

Please Consult with MMD Sales Department for any other Parameters or Options

Mechanical Details

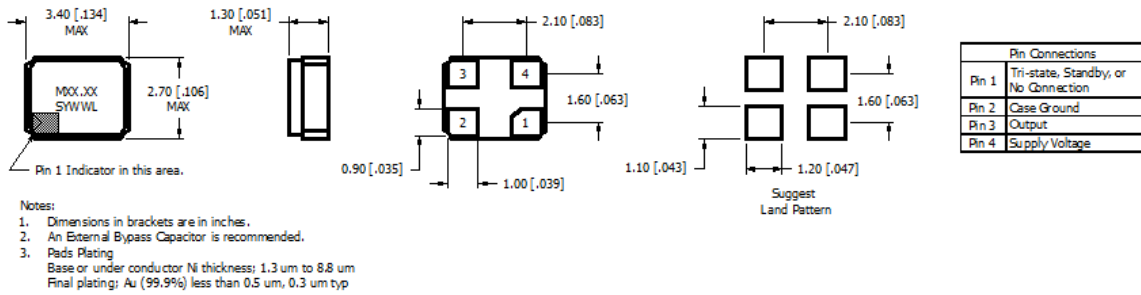

Tape & Reel Dimensions

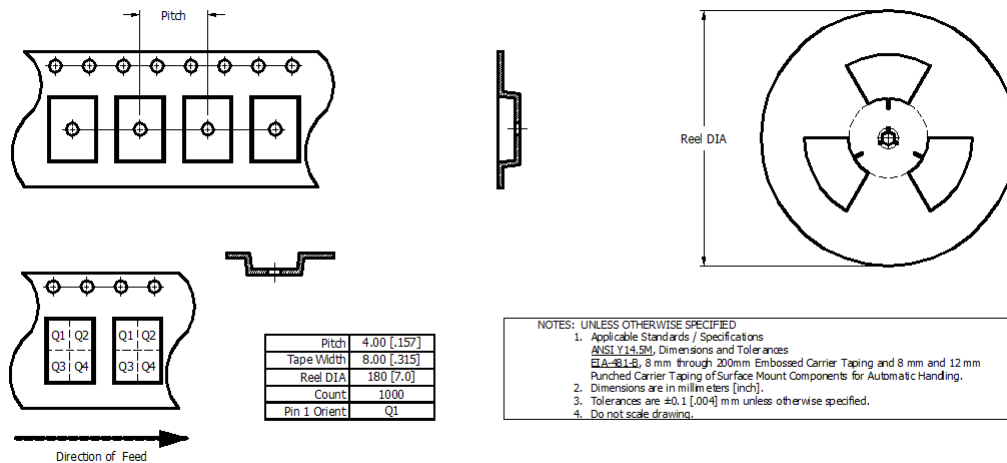

QUALITY SYSTEM
CERTIFIED
= ISO 9001 =

