

FEATURES	APPLICATIONS
<ul style="list-style-type: none"> <li>±20ppm (Frequency Stability) Available</li> <li>Ceramic Package</li> <li>LVPECL</li> <li>RoHS Compliant</li> <li>Programmed Oscillator</li> <li>Tape and Reel</li> </ul>	<ul style="list-style-type: none"> <li>Micro Processors</li> <li>FPGA</li> <li>Storage Area/Networking</li> <li>Digital Video</li> <li>SONET/SDH</li> </ul>



PART NUMBERING GUIDE	
<p><b>SUNTSU QUICK TURN OSC</b> → SQG 53 P 3 A 48 1 - 156.250M ← <b>FREQUENCY (MHz)</b></p> <p><b>5.0 mm x 3.2mm</b></p> <p><b>LVPECL</b></p> <p><b>SUPPLY VOLTAGE</b> 2: 2.5V±5% 3: 3.3V±5%</p> <p><b>FREQUENCY STABILITY</b> A: ±50ppm B: ±30ppm C: ±25ppm *D: ±20ppm</p>	<p><b>TRI-STATE (ENABLE/DISABLE)</b> 1: Pin 1 2: Pin 2</p> <p><b>OPERATING TEMPERATURE RANGE</b> 07: 0°C to +70°C 16: -10°C to +60°C 17: -10°C to +70°C 27: -20°C to +70°C 38: -30°C to +85°C 48: -40°C to +85°C</p>
<p>Cage Code: 4GUT4 To customize your parameters contact a Suntsu representative. * For frequency stability option D contact a Suntsu representative.</p>	

ELECTRICAL PARAMETERS	UNITS	MIN.	TYP.	MAX.	REMARKS
Frequency Range	MHz	8		1500	
Frequency Stability (Includes Initial Tolerance at 25°C, Frequency Stability over Operating Temperature, Output Load Change, Supply Voltage Change, and First Year Aging at 25°C.)	ppm	-20		+20	See part numbering guide for options.
Operating Temperature	°C	-40		+85	See part numbering guide for options.
Storage Temperature		-55		+125	
Supply Voltage (V <sub>DD</sub> )	2.5V Option	2.375	2.5	2.625	
	3.3V Option	3.135	3.3	3.465	
Current (I <sub>DD</sub> )	2.5V Option			65	
	3.3V Option			70	
Output Load (LVPECL)	Ω			50	50 Ω into V <sub>DD</sub> -2.0V <sub>DC</sub> .
Output Logic Levels	Output Logic High (V <sub>OH</sub> )	V <sub>DD</sub> -1.025			
	Output Logic Low (V <sub>OL</sub> )			V <sub>DD</sub> -1.620	
Rise (T <sub>R</sub> ) and Fall (T <sub>F</sub> ) Time	ns			1	
Symmetry (Duty Cycle)	%	45	50	55	
Tri-State Input Voltage	Enable	0.7*V <sub>DD</sub>			No Connection.
	Disable			0.3*V <sub>DD</sub>	
Start-Up Time	ms			10	
Phase Jitter (12kHz ~ 20MHz)	ps		0.7	1.5	

OUTLINE DRAWING															
	<p>RECOMMENDED LAND PATTERN</p> <table border="1"> <thead> <tr> <th>PIN</th> <th>FUNCTION</th> </tr> </thead> <tbody> <tr> <td>1</td> <td>TRI-STATE or NC</td> </tr> <tr> <td>2</td> <td>TRI-STATE or NC</td> </tr> <tr> <td>3</td> <td>GND</td> </tr> <tr> <td>4</td> <td>OUTPUT</td> </tr> <tr> <td>5</td> <td>COMP OUTPUT</td> </tr> <tr> <td>6</td> <td>V<sub>DD</sub></td> </tr> </tbody> </table>	PIN	FUNCTION	1	TRI-STATE or NC	2	TRI-STATE or NC	3	GND	4	OUTPUT	5	COMP OUTPUT	6	V <sub>DD</sub>
PIN	FUNCTION														
1	TRI-STATE or NC														
2	TRI-STATE or NC														
3	GND														
4	OUTPUT														
5	COMP OUTPUT														
6	V <sub>DD</sub>														
<p>NOTE: Dimensions in millimeters (mm).</p>															

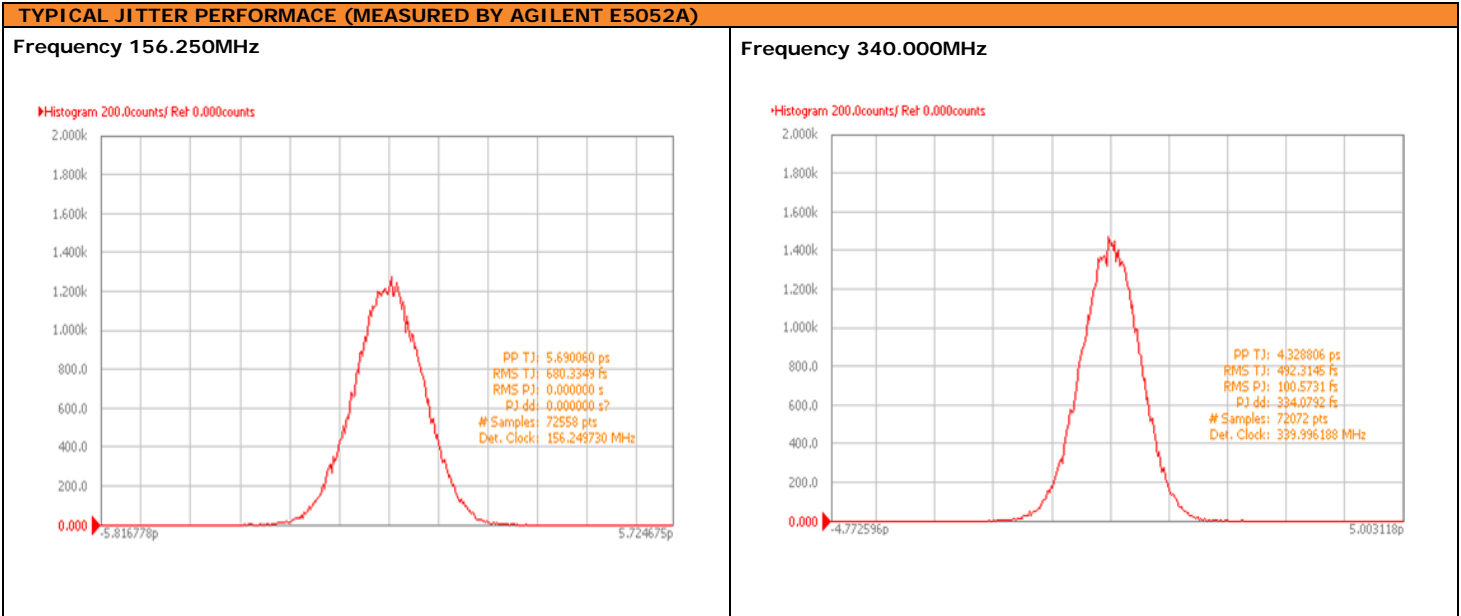
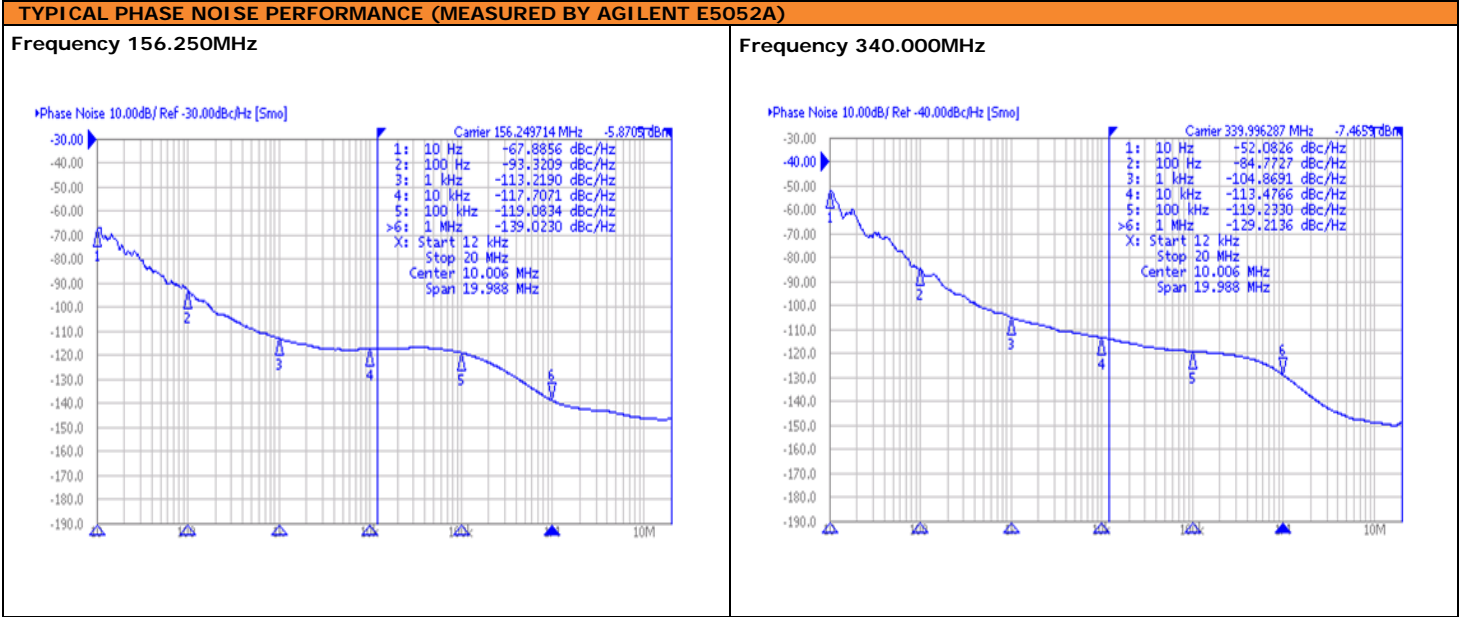
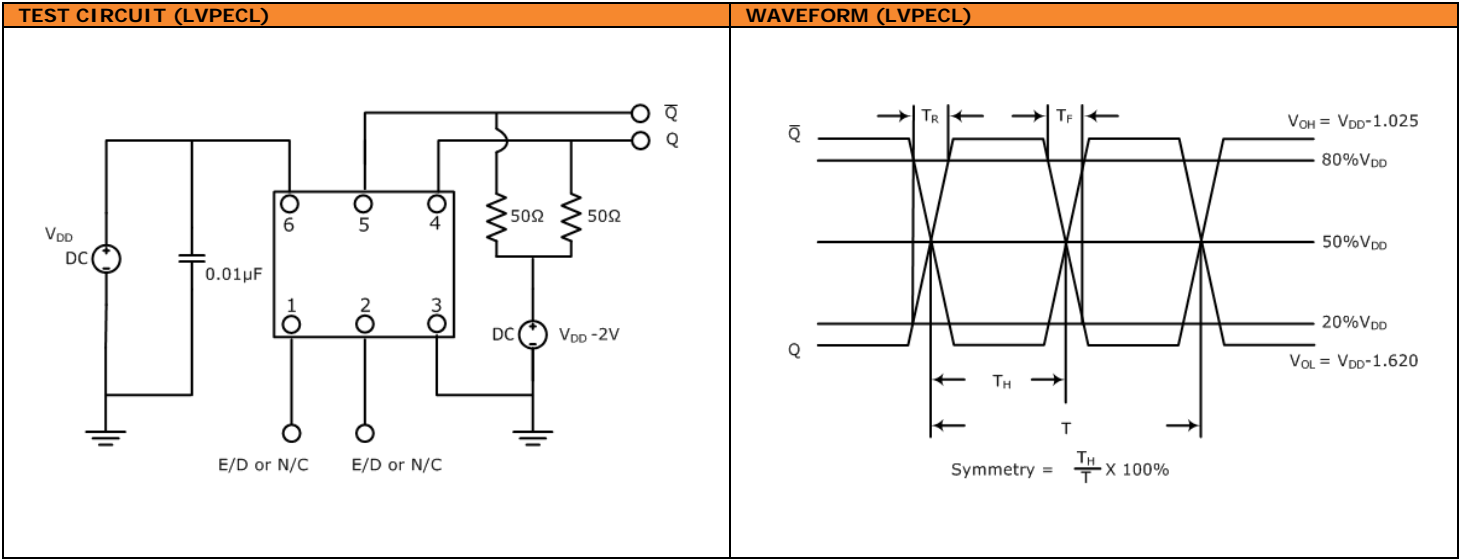

### ENVIRONMENTAL & MECHANICAL SPECIFICATIONS

Temperature Cycling	MIL-STD-883, Method 1010, Condition B
Fine Leak Test	MIL-STD-883, Method 1014, Condition A
Gross Leak Test	MIL-STD-883, Method 1014, Condition C
Mechanical Shock	MIL-STD-883, Method 2002, Condition B
Vibration	MIL-STD-883, Method 2007, Condition A
Moisture Resistance	MIL-STD-883, Method 1004
Moisture Sensitivity	J-STD-020, MSL 1
Resistance to Soldering Heat	MIL-STD-202, Method 210, Condition K
Resistance to Solvents	MIL-STD-202, Method 215
Solderability	MIL-STD-883, Method 2003

### REFLOW PROFILE

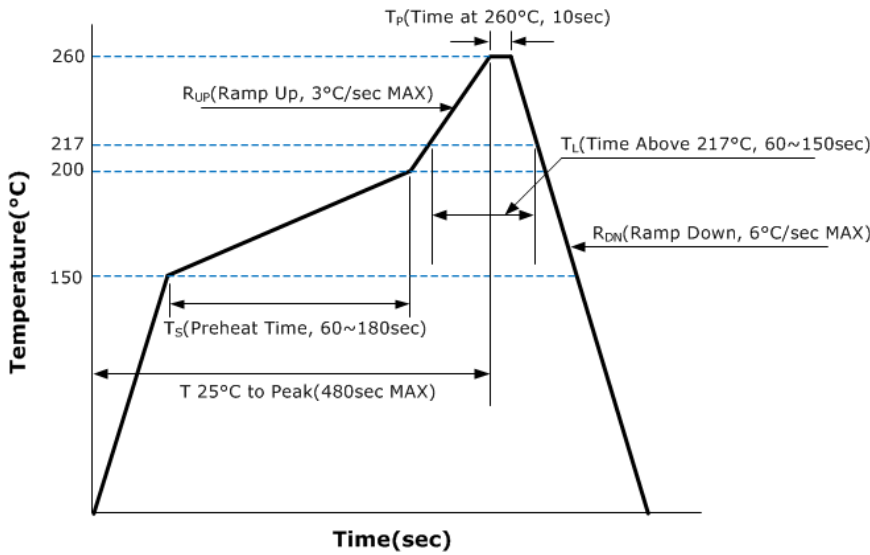

### MARKING

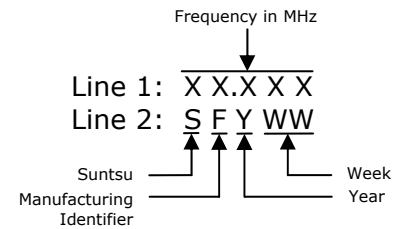

### TAPE AND REEL DIMENSIONS

1,000pcs/reel

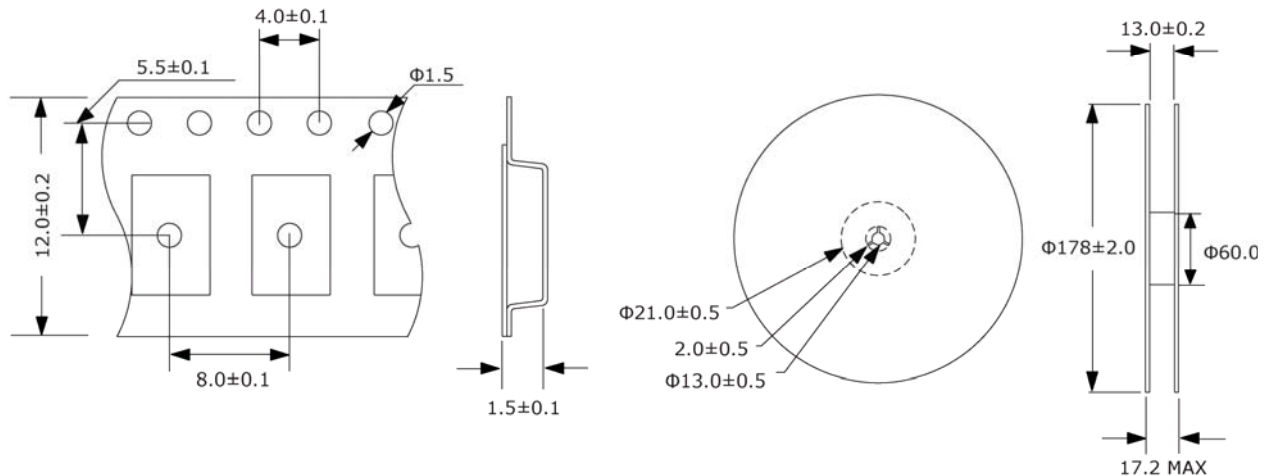

NOTE: Dimensions in millimeters (mm); drawing is not to scale.