

Product Features:

- Wide Temperature Range (-55° to +125°C)
- Frequency Stability option ±50 ppm over the full operating temperature range.
- Low Phase Noise
- RoHS Compliant

Frequency	1.000 MHz to 125.000 MHz
Output Level CMOS	Logic '0' = 10% of Vcc max Logic '1' = 90% of Vcc min
Duty Cycle	Specify 50% ±10% or ±5% See Table in Part Number Guide
Rise / Fall Time	5 nS Max. for 10% to 90% of waveform
Output Load	15 pF
Frequency Stability	See Frequency Stability Table (Includes room temperature tolerance and stability over operating temperature)
Aging (Initial First Year)	±3 ppm max
Start-up Time	5 mS Max.
Supply Voltage	See Input Voltage Table, tolerance ±5 %
Current	50 mA Max.
Operating	-55° C to +125° C
Storage	-55° C to +125° C
Phase Jitter: (12kHz - 20MHz)	1 pS RMS max
Tri-State (Pin 1) Function Enable / Disable Time Current, Standby Mode	Standby 100 nS Max. N.C. or ≥ 70% Vcc = Enable. ≤ 30% Vcc = Disable 20 µA

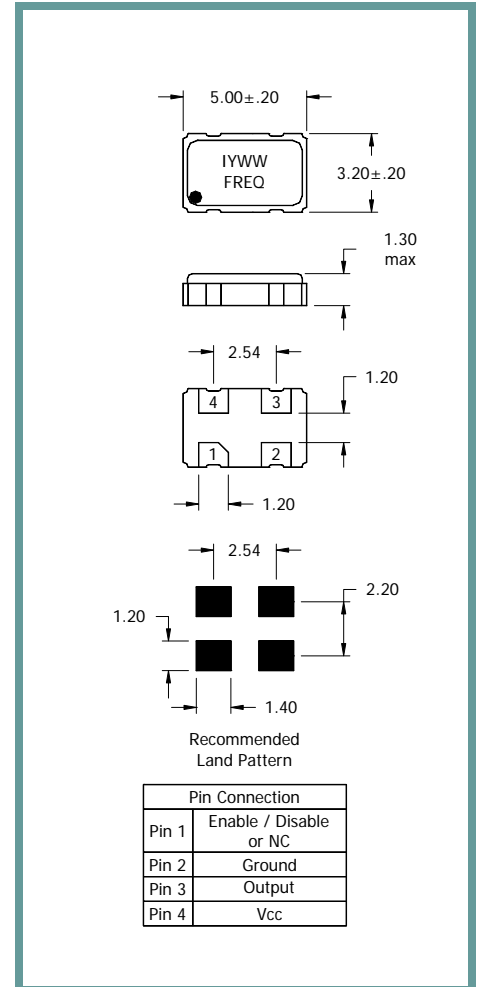

Part Number Guide		Sample Part Number:			ISM82-3756BH-20.000		
Package	Input Voltage	Operating Temperature	Symmetry (Duty Cycle)	Output	Stability (in ppm)	Enable / Disable	Frequency
ISM82	1 = 1.8 V	7 = -55°C to +125°C	5 = 45 / 55 max	3 = 15pF	B = ±50 ppm	H = Enable	20.000
	2 = 2.7 V		6 = 40 / 60 max	6 = 30pF *	C = ±100 ppm	O = N/C	
	3 = 3.3 V						
	6 = 2.5 V						
	7 = 3.0 V						

*Oscillator may not meet 5% symmetry over temperature range with 30 pF load.

NOTE: A 0.01 µF bypass capacitor is recommended between Vcc (pin 4) and GND (pin 2) to minimize power supply noise.

Pb Free Solder Reflow Profile:

Typical Application:

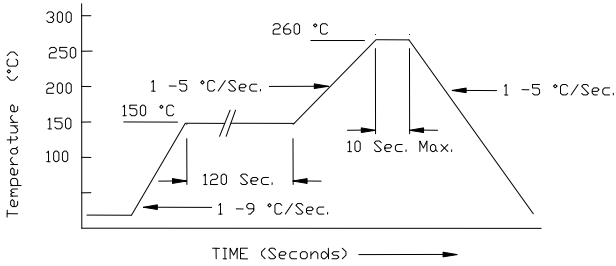

*Units are backward compatible with 240° C reflow processes

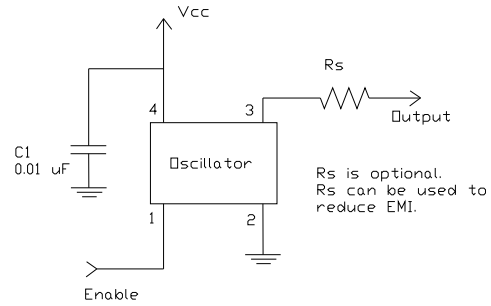

Package Information:

MSL = N.A. (Package does not contain plastic; storage life is unlimited under normal room conditions.)
Termination = e4 (Au over Ni over W base metallization).

Tape and Reel Information:

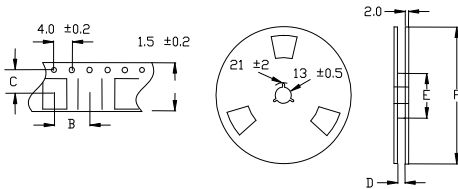

Quantity per Reel	1000
A	16 +/- .3
B	8 +/- .2
C	7.5 +/- .2
D	17.5 +/- .1
E	50 / 60 / 80
F	180 / 250

Environmental Specifications:

Thermal Shock	MIL-STD-883, Method 1011, Condition A
Moisture Resistance	MIL-STD-883, Method 1004
Mechanical Shock	MIL-STD-883, Method 2002, Condition B
Mechanical Vibration	MIL-STD-883, Method 2007, Condition A
Resistance to Soldering Heat	J-STD-020C, Table 5-2 Pb-free devices (except 2 cycles max)
Hazardous Substance	Pb-Free / RoHS / Green Compliant
Solderability	JESD22-B102-D Method 2 (Preconditioning E)
Terminal Strength	MIL-STD-883, Method 2004, Test Condition D
Gross Leak	MIL-STD-883, Method 1014, Condition C
Fine Leak	MIL-STD-883, Method 1014, Condition A2, R1=2x10 ⁻⁸ atm cc/s
Solvent Resistance	MIL-STD-202, Method 215

Marking:

Line 1: ILSI and Date Code (YWW)
Line 2: Frequency

Proprietary and Confidential

This document contains proprietary information, and such information may not be disclosed to others for any purpose nor used for manufacturing purpose without the written permission of ILSI America.