



## SM77D Series 1.8 V CMOS Clock Oscillators

January 2016



- Pletronics' SM77D Series is a quartz crystal controlled precision square wave generator with a CMOS output.
- The SM77D series will directly interface TTL devices also.
- The package is designed for high density surface mount designs.
- This is a low cost mass produced oscillator.
- Tape and Reel or cut tape packaging is available.
- 70 to 165 MHz
- 5 x 7 mm LCC Ceramic Package
- Enable/Disable Function
- Disable function includes low standby power mode
- 3<sup>rd</sup> Overtone Crystals used
- Improved circuit to minimize oscillator issues such as multi-mode output signal.
- Low Jitter
- Capable of driving up to 15pF capacitive loads

**Pletronics Inc. certifies this device is in accordance with the  
RoHS 6/6 (2011/65/EC) and WEEE (2002/96/EC) directives.**

Pletronics Inc. guarantees the device does not contain the following:

Cadmium, Hexavalent Chromium, Lead, Mercury, PBB's, PBDE's

Weight of the Device: 0.17 grams

Moisture Sensitivity Level: 1 As defined in J-STD-020C

Second Level Interconnect code: e4

### Absolute Maximum Ratings:

Parameter	Unit
V <sub>CC</sub> Supply Voltage	-0.5V to +5.0V
V <sub>i</sub> Input Voltage	-0.5V to V <sub>CC</sub> + 0.5V
V <sub>o</sub> Output Voltage	-0.5V to V <sub>CC</sub> + 0.5V

### Thermal Characteristics

The maximum die or junction temperature is 155°C

The thermal resistance junction to board is 30 to 50°C/Watt depending on the solder pads, ground plane and construction of the PCB.

## Part Number:

SM77	45	D	E	X	-100.0M	-XX	
							<b>Packaging code or blank</b> <b>T250</b> = 250 per Tape and Reel <b>T500</b> = 500 per Tape and Reel <b>T1K</b> = 1,000 per Tape and Reel
							<b>Frequency in MHz</b>
							<b>Supply Voltage <math>V_{CC}</math></b> <b>X</b> = 1.8V $\pm$ 5%
							<b>Optional Enhanced OTR</b> <b>Blank</b> = Temp. range -10 to +70°C <b>C</b> = Temp. range -20 to +70°C <b>E</b> = Temp. range -40 to +85°C
							<b>Series Model</b>
							<b>Frequency Stability</b> <b>45</b> = $\pm$ 50 ppm <b>44</b> = $\pm$ 25 ppm <b>20</b> = $\pm$ 20 ppm
							<b>Series Model</b>

## Part Marking and Marking Legend:

PLE SM77 FF.FFF M • YMDxx	PLE SM77 FF.FFF M • YYWWxx	7xYWWxx FF.FFF M • PLE xxx
---------------------------------	----------------------------------	----------------------------------

PLE = Pletronics  
 FF.FFF M = Frequency in MHz  
 YYWW or YWW or YMD = Date of Manufacture (year and week, or year-month-day)  
 All other marking is internal factory codes

Specifications such as frequency stability, supply voltage and operating temperature range, etc. are not identified from the marking. External packaging labels and packing list will correctly identify the ordered Pletronics part number.

### Codes for Date Code YMD

Code	4	5	6	7	8	Code	A	B	C	D	E	F	G	H	J	K	L	M
Year	2014	2015	2016	2017	2018	Month	JAN	FEB	MAR	APR	MAY	JUN	JUL	AUG	SEP	OCT	NOV	DEC

Code	1	2	3	4	5	6	7	8	9	A	B	C	D	E	F	G
Day	1	2	3	4	5	6	7	8	9	10	11	12	13	14	15	16
Code	H	J	K	L	M	N	P	R	T	U	V	W	X	Y	Z	
Day	17	18	19	20	21	22	23	24	25	26	27	28	29	30	31	

## Electrical Specification for 1.80V $\pm 10\%$ over the specified temperature range

Item	Min	Max	Unit	Condition
Frequency Range	70	165	MHz	
Frequency Accuracy "45"	-50	+50	ppm	For all supply voltages, load changes, aging for 1 year, shock, vibration and temperatures
"44"	-25	+25		
"20"	-20	+20		
Output Waveform	CMOS			
Output High Level	0.4	-	V	Below $V_{CC}$ (See load circuit)
Output Low Level	-	0.4	V	(See load circuit)
Output Symmetry	45	55	%	at 50% point of $V_{CC}$ (See load circuit)
Jitter	-	0.6	pS RMS	12 KHz to 20 MHz from the output frequency
	-	2.5	pS RMS	10 Hz to 1 MHz from the output frequency
Enable/Disable Internal Pull-up	30	-	Kohm	to $V_{CC}$
V disable	-	30	%	of $V_{CC}$ applied to pad 1
V enable	70	-	%	
Output leakage $V_{OUT} = V_{CC}$	-10	+10	uA	Pad 1 low, device disabled
$V_{OUT} = 0V$	-10	+10	uA	
Standby Current $I_{CC}$	-	10	uA	
Enable time	-	2.0	mS	Time for output to resume operation
Disable time	-	200	nS	Time for output to reach a high Z state
Start up time	-	5	mS	Time for output to reach specified frequency
Operating Temperature Range	-10	+70	°C	Standard Temperature Range
	-20	+70	°C	Extended Temperature Range "C" Option
	-40	+85	°C	Extended Temperature Range "E" Option
Storage Temperature Range	-55	+125	°C	

## Electrical Specification for 1.80V $\pm 10\%$ over the specified temperature range

Item	Min	Typ	Max	Unit	Condition	
$V_{OUT}$ High ( $V_{OH}$ )	0.4	0.3	-	V	Below $V_{CC}$ , $I_{OH} = +8$ mA	
$V_{OUT}$ Low ( $V_{OL}$ )	-	0.3	0.4	V	$I_{OL} = -8$ mA	
Output $T_{RISE}$ and $T_{FALL}$	-	1.5	2.5	nS	$C_{LOAD} = 15$ pF 20% to 80% of $V_{CC}$ (See load circuit)	
$V_{CC}$ Supply Current ( $I_{CC}$ )	-	21	33	mA	>125 MHz	$C_{LOAD} = 15$ pF 20% to 80% of $V_{CC}$ (See load circuit)
	-	17	27	mA	>95 MHz and $\leq 125$ MHz	
	-	11	19	mA	$\leq 95$ MHz	

Specifications with Pad 1 E/D open circuit

## Load Circuit and Test Waveform

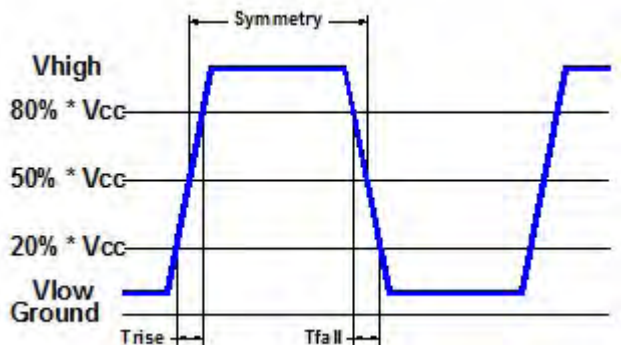
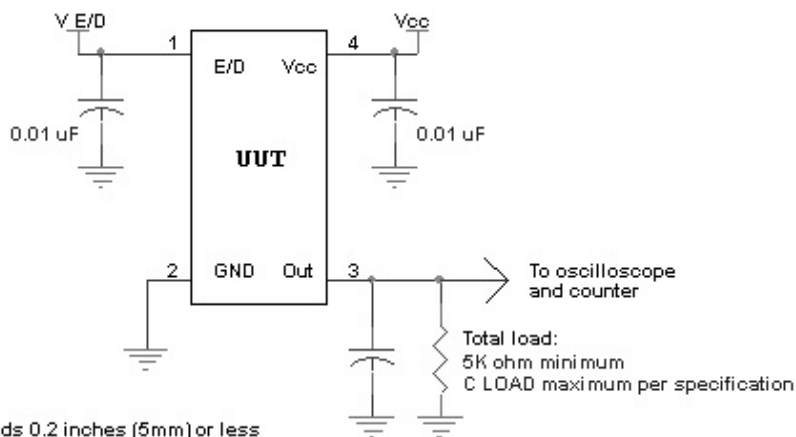

## Reliability: Environmental Compliance

Parameter	Condition
Mechanical Shock	MIL-STD-883 Method 2002, Condition B
Vibration	MIL-STD-883 Method 2007, Condition A
Solderability	MIL-STD-883 Method 2003
Thermal Shock	MIL-STD-883 Method 1011, Condition A

## ESD Rating

Model	Minimum Voltage	Conditions
Human Body Model	1500	MIL-STD-883 Method 3115
Charged Device Model	1000	JESD 22-C101

## Package Labeling

Label is 1" x 2.6" (25.4mm x 66.7mm)  
Font is Courier New  
Bar code is 39-Full ASCII

Label is 1" x 2.6" (25.4mm x 66.7mm)  
Font is Arial

P/N:		
	SM7745DX-106.25M	
Customer P/N:		
	12345678	
Qty:		D/C 
	1000	75409MM

RoHS Compliant
2nd LvL Interconnect
Category=e4
Max Safe Temp=260C for 10s 2X Max

## Mechanical:

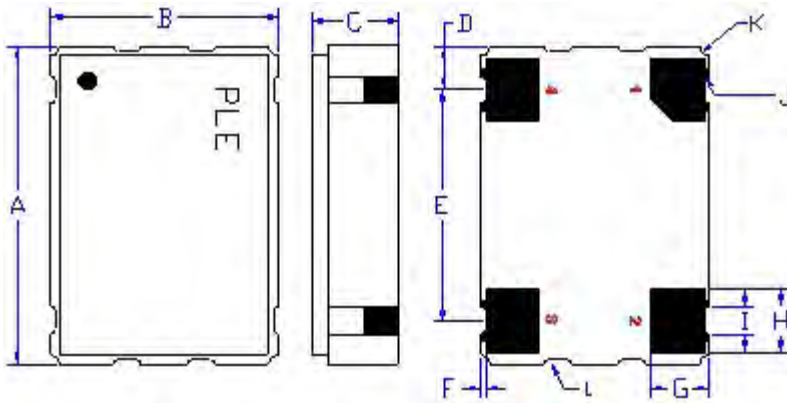

	Inches	mm
A	0.276 ±0.006	7.00 ±0.15
B	0.197 ±0.006	5.00 ±0.15
C	0.068 ±0.018	1.73 ±0.44
D <sup>1</sup>	0.038	0.96
E <sup>1</sup>	0.200	5.08
F <sup>1</sup>	0.004	0.10
G <sup>1</sup>	0.050	1.27
H <sup>1</sup>	0.055	1.40
I <sup>1</sup>	0.024	0.60
J <sup>1</sup>	0.004	0.10R
K <sup>1</sup>	0.008	0.020R

The detents marked "L" on the package ends are optional

Not to Scale

<sup>1</sup> Typical dimensions

Contacts (pads) :

Gold 11.8 to 39.4 μinches (0.3 to 1.0 μm) over Nickel 50 to 350 μinches (1.27 to 8.89 μm)

Pad	Function	Note
1	Output Enable/Disable	When this pad is not connected the oscillator shall operate. When this pad is logic low the output will be inhibited (high impedance state.) Recommend connecting this pad to V <sub>CC</sub> if the oscillator is to be always on.
2	Ground (GND)	
3	Output	
4	Supply Voltage (V <sub>CC</sub> )	Recommend connecting appropriate power supply bypass capacitors as close as possible.

## Layout and application information



For Optimum Jitter Performance, Pletronics recommends:

- a ground plane under the device
- no large transient signals (both current and voltage) should be routed under the device
- do not layout near a large magnetic field such as a high frequency switching power supply
- do not place near piezoelectric buzzers or mechanical fans.

## Reflow Cycle (typical for lead free processing)

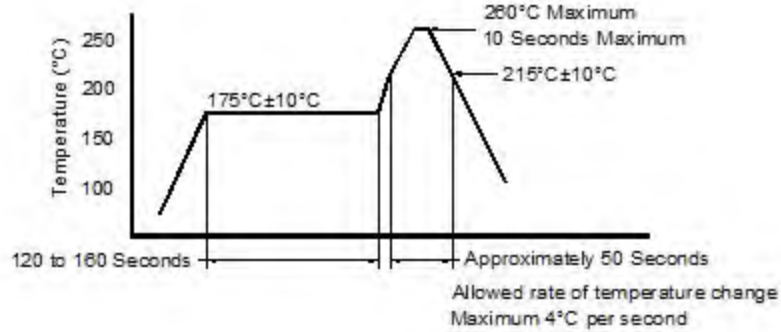

The part may be reflowed 3 times without degradation.

## Tape and Reel: available for quantities of 250 to 1000 per reel (< 250 = cut tape)

Constant Dimensions Table 1								
Tape Size	D0	D1 Min	E1	P0	P2	S1 Min	T Max	T1 Max
8mm	1.5	1.0	1.75	4.0	2.0 ± 0.05	0.6	0.6	0.1
12mm		1.5			2.0 ± 0.1			
16mm	+0.1 -0.0	1.5	± 0.1	± 0.1	2.0 ± 0.1			
24mm		1.5						

Variable Dimensions Table 2							
Tape Size	B1 Max	E2 Min	F	P1	T2 Max	W Max	Ao, Bo & Ko
16 mm	12.1	14.25	7.5 ± 0.1	8.0 ± 0.1	8.0	16.3	Note 1

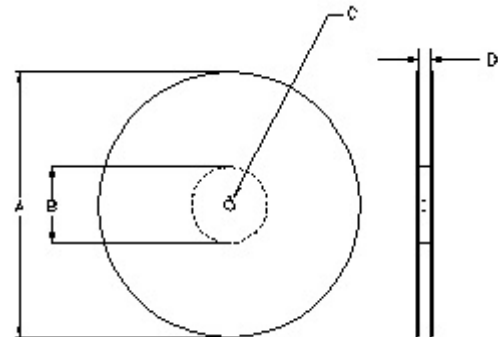

Note 1: Embossed cavity to conform to EIA-481-B      Dimensions in mm      Not to scale

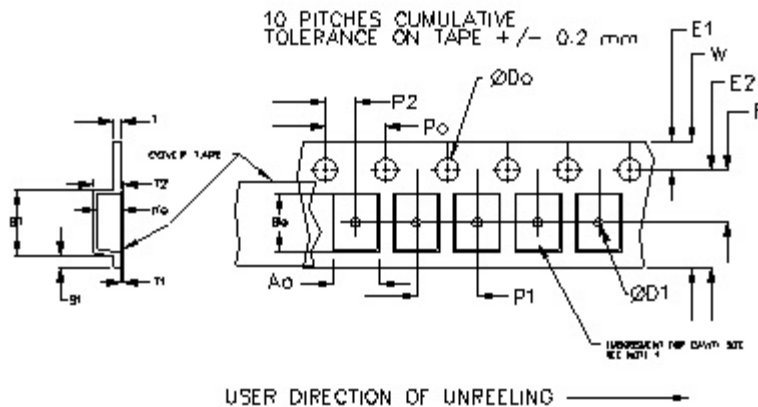

		REEL DIMENSIONS			
A	inches	7.0	10.0	13.0	
	mm	177.8	254.0	330.2	
B	inches	2.50	4.00	3.75	
	mm	63.5	101.6	95.3	Tape Width
C	mm	13.0 +0.5 / -0.2			
D	mm	16.4 +2.0 -0.0	16.4 +2.0 -0.0	16.4 +2.0 -0.0	16.0

Reel dimensions may vary from the above