



## LV77K Series 2.5 V LVDS Clock Oscillators

April 2017

**Lead Free**

- Pletronics' LV77K Series is a quartz crystal controlled precision square wave generator with LVDS output.
- Improved phase noise performance.
- Tape and Reel or cut tape packaging is available.
- 5 x 7 mm LCC Ceramic Package
- Enable/Disable Function on pad 1
- Disable function includes low standby power mode
- 3<sup>rd</sup> Overtone Crystals used
- Improved circuit to minimize oscillator issues such as multi-mode output signal.
- Lowest Jitter Product

**\* BEST OPTION FOR LOW JITTER REQUIREMENTS**  
**50 fS Jitter 12 KHz - 20 MHz @ 156.25 MHz**

**Pletronics Inc. certifies this device is in accordance with the  
RoHS 6/6 (2011/65/EC) and WEEE (2002/96/EC) directives.**

Pletronics Inc. guarantees the device does not contain the following:

Cadmium, Hexavalent Chromium, Lead, Mercury, PBB's, PBDE's

Weight of the Device: 0.16 grams

Moisture Sensitivity Level: 1 As defined in J-STD-020D.1

Second Level Interconnect code: e4

### Absolute Maximum Ratings:

Parameter	Unit
V <sub>CC</sub> Supply Voltage	-0.5V to +4.6V
V <sub>i</sub> Input Voltage	-0.5V to V <sub>CC</sub> + 0.5V
V <sub>o</sub> Output Voltage	-0.5V to V <sub>CC</sub> + 0.5V

### Thermal Characteristics

The maximum die or junction temperature is 125°C

The thermal resistance junction to board is 30 to 50°C/Watt depending on the solder pads, ground plane and construction of the PCB.

### Part Number:

LV77	45	K	E	W	-125.0M	-XX		
								<b>Available Frequencies:</b>  100.0MHz  106.25MHz  125.0MHz  133.0MHz  156.25MHz  Contact factory for other options
<b>Packaging code or blank</b> T250 = 250 per Tape and Reel T500 = 500 per Tape and Reel T1K = 1000 per Tape and Reel								
<b>Frequency in MHz</b>								
<b>Supply Voltage V<sub>CC</sub></b> W = 2.5V ± 10%								
<b>Optional Enhanced OTR</b> Blank = Temp. range -10 to +70°C C = Temp. range -20 to +70°C E = Temp. range -40 to +85°C								
<b>Series Model</b>								
<b>Frequency Stability</b> 45 = ± 50 ppm 44 = ± 25 ppm 20 = ± 20 ppm								
<b>Series Model</b>								

### Part Marking:

PLE LV77 FF.FFF M • YMDXX	or	LV7XYWWXX FF.FFF M • PLE XXX
---------------------------------	----	------------------------------------

#### Marking Legend:

PLE = Pletronics

FF.FFF M = Frequency in MHz

YYWW or YWW or YMD = Date of Manufacture (year and week, or year-month-day)

All other marking is internal factory codes

Specifications such as frequency stability, supply voltage and operating temperature range, etc. are not identified from the marking. External packaging labels and packing list will correctly identify the ordered Pletronics part number.

#### Codes for Date Code YMD

Code	4	5	6	7	8	Code	A	B	C	D	E	F	G	H	J	K	L	M
Year	2014	2015	2016	2017	2018	Month	JAN	FEB	MAR	APR	MAY	JUN	JUL	AUG	SEP	OCT	NOV	DEC

Code	1	2	3	4	5	6	7	8	9	A	B	C	D	E	F	G
Day	1	2	3	4	5	6	7	8	9	10	11	12	13	14	15	16
Code	H	J	K	L	M	N	P	R	T	U	V	W	X	Y	Z	
Day	17	18	19	20	21	22	23	24	25	26	27	28	29	30	31	

## Electrical Specification for 2.50V $\pm 5\%$ over the specified temperature range and the frequency range of 100.0 to 212.50 MHz

Item	Min	Typ	Max	Unit	Condition
Frequency Accuracy "45"	-50	-	+50	ppm	For all supply voltages, load changes, aging for 1 year, shock, vibration and temperatures
"44"	-25	-	+25		
"20"	-20	-	+20		
Output Waveform	LVDS				
Output High Level	-	1.43	1.60	V	
Output Low Level	0.90	1.10	-	V	
Output Symmetry	45	-	55	%	at 50% point of $V_{CC}$ (See load circuit)
Jitter <sup>1</sup>	-	50	-	fs RMS	12 KHz to 20 MHz from the output frequency @ 156.25 MHz
Output $T_{RISE}$ and $T_{FALL}$	-	0.3	1.0	ns	Vth is 20% and 80% of waveform
$V_{CC}$ Supply Current ( $I_{CC}$ )	-	28	45	mA	
Enable/Disable Internal Pull-up	30	-	150	Kohm	to $V_{CC}$ , measured with Pad 1 = 0.0 volts
V disable	-	-	20	%Vcc	
V enable	80	-	-	%Vcc	
Output leakage Current	-10	-	+10	$\mu$ A	
Enable time	-	-	2	ms	Time for output to reach a logic state, the output frequency is correct at the specified Start Time.
Disable time	-	-	200	ns	Time for output to reach a high Z state
Start up time	-	-	3	ms	Time for output to reach specified frequency
Operating Temperature Range	-10	-	+70	$^{\circ}$ C	Standard Temperature Range
	- 20	-	+70	$^{\circ}$ C	Extended Temperature Range "C" Option
	- 40	-	+85	$^{\circ}$ C	Extended Temperature Range "E" Option
Storage Temperature Range	-55	-	+125	$^{\circ}$ C	
Standby Current $I_{CC}$	-	-	15	$\mu$ A	Pad 1 low, device disabled

<sup>1</sup> Jitter computed from phase noise data at 156.25MHz

Specifications with Pad 1 E/D open circuit unless stated otherwise

## Load Circuit

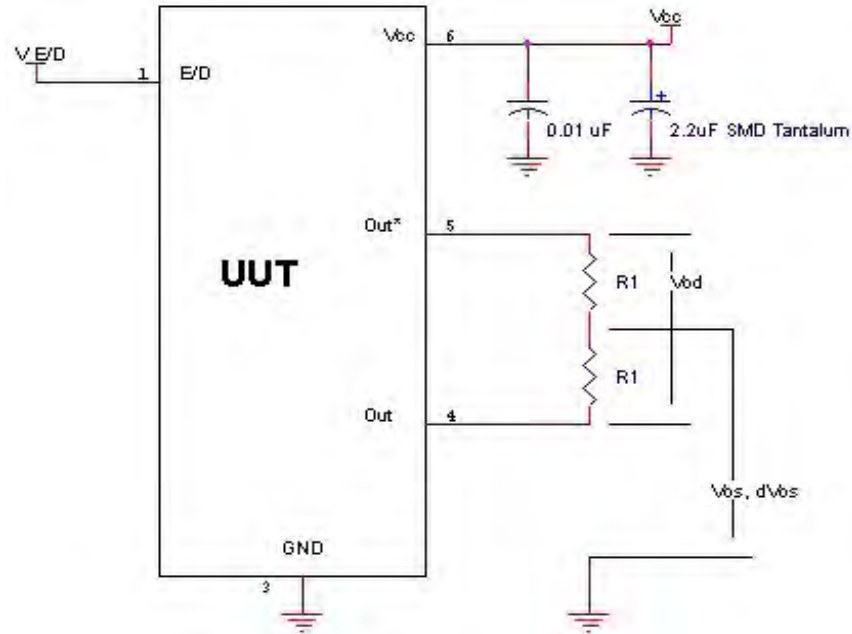

## Test Waveform

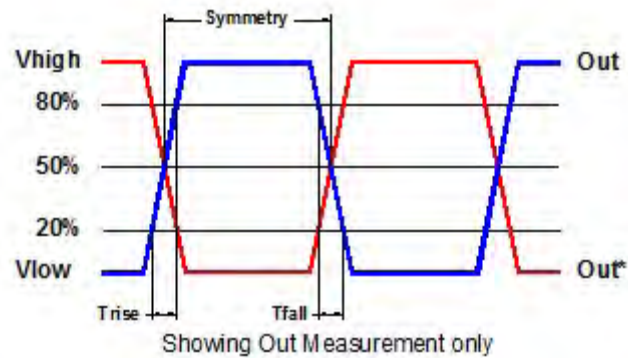

## Reliability: Environmental Compliance

Parameter	Condition
Mechanical Shock	MIL-STD-883 Method 2002, Condition B
Vibration	MIL-STD-883 Method 2007, Condition A
Solderability	MIL-STD-883 Method 2003
Thermal Shock	MIL-STD-883 Method 1011, Condition A

## ESD Rating

Model	Minimum Voltage	Conditions
Human Body Model	1500	MIL-STD-883 Method 3115
Charged Device Model	1000	JESD 22-C101

## Package Labeling

Label is 1" x 2.6" (25.4mm x 66.7mm)  
Font is Courier New  
Bar code is 39-Full ASCII

Label is 1" x 2.6" (25.4mm x 66.7mm)  
Font is Arial

<b>P/N:</b>  LV7745KW-156.25M <b>Customer P/N:</b>  12345678 <b>Qty:</b>  1000 <b>D/C</b>  6KX-SG MSL: 1
---

<b>RoHS Compliant</b> 2nd LvL Interconnect Category=e4 Max Safe Temp=260C for 10s 2X Max
---

## Mechanical:

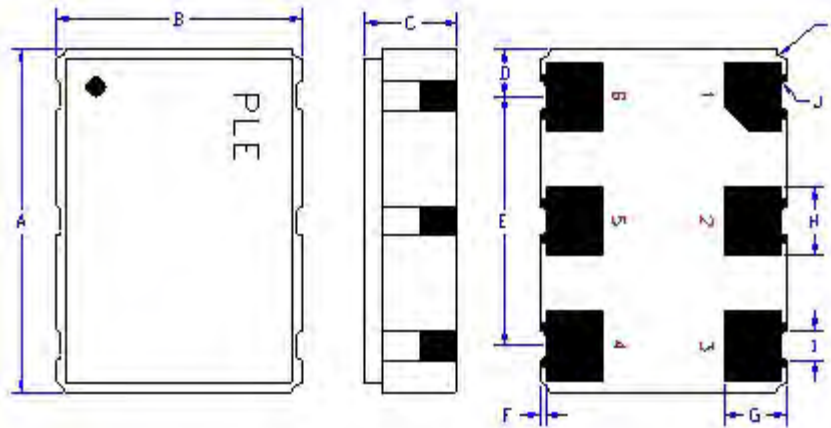

Not to Scale

<sup>1</sup> Typical dimensions

	Inches	mm
A	0.276 ±0.006	7.00 ±0.15
B	0.197 ±0.006	5.00 ±0.15
C	0.067 max	1.80 max
D <sup>1</sup>	0.038	0.96
E <sup>1</sup>	0.200	5.08
F <sup>1</sup>	0.004	0.10
G <sup>1</sup>	0.050	1.27
H <sup>1</sup>	0.055	1.40
I <sup>1</sup>	0.024	0.60
J <sup>1</sup>	0.004R	0.10R
K <sup>1</sup>	0.008R	0.20R

## Contacts (pads) :

Gold 11.8 to 39.4 μmches (0.3 to 1.0 μm) over Nickel 50 to 350 μmches (1.27 to 8.89 μm)

Pad	Function	Note
1	Output Enable/Disable	When this pad is not connected the oscillator shall operate. When this pad is <0.30 volts, the output will be inhibited (high impedance state.) Recommend connecting this pad to V <sub>CC</sub> if the oscillator is to be always on.
2	No connect	There is no internal connection to this pad
3	Ground (GND)	
4	Output	Both outputs must be terminated and biased for proper operation. The ideal termination is 50 ohms connected to 2.0V below the Supply Voltage.
5	Output*	
6	Supply Voltage (V <sub>CC</sub> )	Recommend connecting appropriate power supply bypass capacitors as close as possible.



## Layout and application information

Recommend connecting Pad 1 and Pad 2 together to permit the design to accept Enable/Disable input on either pad

For Optimum Jitter Performance, Pletronics recommends:

- a ground plane under the device
- no large transient signals (both current and voltage) should be routed under the device
- do not layout near a large magnetic field such as a high frequency switching power supply
- do not place near piezoelectric buzzers or mechanical fans.

## Reflow Cycle (typical for lead free processing)

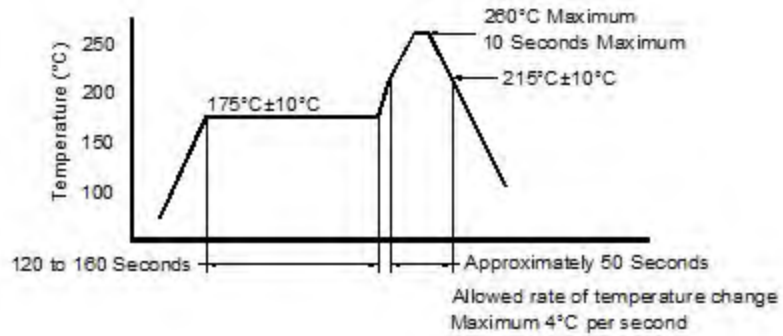

The part may be reflowed 3 times without degradation.

## Tape and Reel: available for quantities of 250 to 1000 per reel, cut tape for < 250

Constant Dimensions Table 1								
Tape Size	D0	D1 Min	E1	P0	P2	S1 Min	T Max	T1 Max
8mm	1.5	1.0	1.75	4.0	2.0 ±0.05	0.6	0.6	0.1
12mm		1.5			2.0 ±0.1			
16mm	+0.1 -0.0	1.5	±0.1	±0.1	2.0 ±0.1	0.6	0.6	0.1
24mm		1.5						

Variable Dimensions Table 2							
Tape Size	B1 Max	E2 Min	F	P1	T2 Max	W Max	Ao, Bo & Ko
16 mm	12.1	14.25	7.5 ± 0.1	8.0 ± 0.1	8.0	16.3	Note 1

Note 1: Embossed cavity to conform to EIA-481-B Dimensions in mm Not to scale

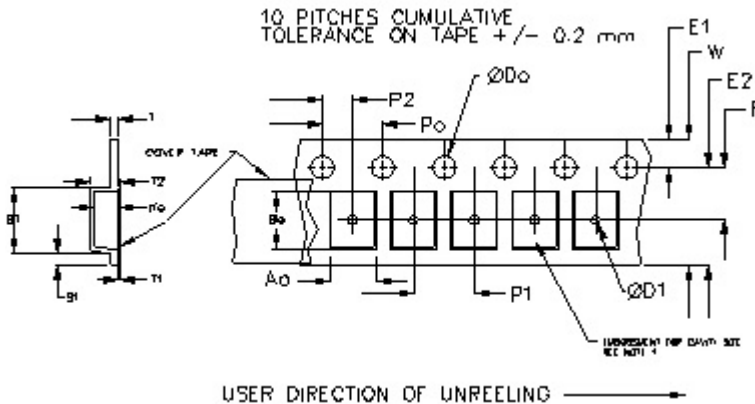
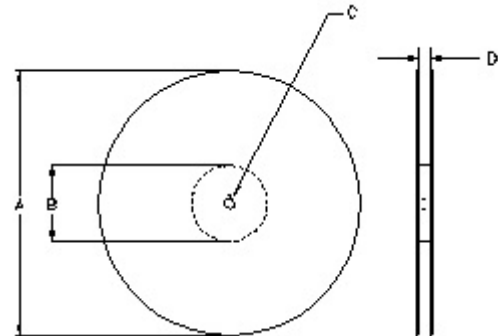

		REEL DIMENSIONS			
A	inches	7.0	10.0	13.0	
	mm	177.8	254.0	330.2	
B	inches	2.50	4.00	3.75	
	mm	63.5	101.6	95.3	Tape Width
C	mm	13.0 +0.5 / -0.2			
D	mm	16.4 +2.0 -0.0	16.4 +2.0 -0.0	16.4 +2.0 -0.0	16.0

Reel dimensions may vary from the above