

TFA16 Series

Automotive Grade Tuning Fork Crystal

Features

- AEC-Q200 Compliant
- Hermetic Ceramic Surface Mount Package
- Tuning Fork Crystal Design
- 32.7680kHz Frequency Reference
- Frequency Tolerance, ± 20 ppm Standard
- Parabolic Temperature Coefficient
- Tape and Reel Packaging, EIA-418

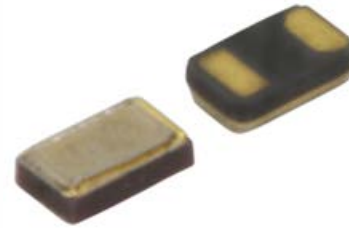

Part Dimensions:
1.6 × 1.0 × 0.5mm • 2.33909mg

Applications

- Automotive Electronics
- Car Navigation Systems
- Car Infotainment Systems
- Industrial Control Equipment
- M2M Communications
- FPGAs & Microcontrollers

Description

CTS TFA16 Series is ideal for supporting wide range of electronic designs requiring a Real Time Clock reference. This series will support general automotive and industrial applications.

Ordering Information

Model	Frequency Tolerance	Load Capacitance	Temperature Range	Frequency Code [kHz]	Packaging																				
TF A16	2	P	I	327K	R																				
<table border="1"> <thead> <tr> <th>Code</th> <th>Package</th> </tr> </thead> <tbody> <tr> <td>A</td> <td>Automotive</td> </tr> <tr> <td>16</td> <td>1.6x1.0mm</td> </tr> </tbody> </table>		Code	Package	A	Automotive	16	1.6x1.0mm	<table border="1"> <thead> <tr> <th>Code</th> <th>Capacitance</th> </tr> </thead> <tbody> <tr> <td>P</td> <td>12.5pF</td> </tr> <tr> <td>J</td> <td>9pF</td> </tr> <tr> <td>V</td> <td>7pF</td> </tr> <tr> <td>W</td> <td>5pF</td> </tr> </tbody> </table>		Code	Capacitance	P	12.5pF	J	9pF	V	7pF	W	5pF	<table border="1"> <thead> <tr> <th>Code</th> <th>Frequency</th> </tr> </thead> <tbody> <tr> <td>327K</td> <td>32.7680kHz</td> </tr> </tbody> </table>		Code	Frequency	327K	32.7680kHz
Code	Package																								
A	Automotive																								
16	1.6x1.0mm																								
Code	Capacitance																								
P	12.5pF																								
J	9pF																								
V	7pF																								
W	5pF																								
Code	Frequency																								
327K	32.7680kHz																								
<table border="1"> <thead> <tr> <th>Code</th> <th>@ +25°C</th> </tr> </thead> <tbody> <tr> <td>2</td> <td>± 20ppm</td> </tr> <tr> <td>1</td> <td>± 10ppm</td> </tr> </tbody> </table>		Code	@ +25°C	2	± 20 ppm	1	± 10 ppm	<table border="1"> <thead> <tr> <th>Code</th> <th>Temp. Range</th> </tr> </thead> <tbody> <tr> <td>I</td> <td>-40°C to +85°C</td> </tr> <tr> <td>G</td> <td>-40°C to +105°C</td> </tr> </tbody> </table>		Code	Temp. Range	I	-40°C to +85°C	G	-40°C to +105°C	<table border="1"> <thead> <tr> <th>Code</th> <th>Packing</th> </tr> </thead> <tbody> <tr> <td>R</td> <td>3k pcs./reel</td> </tr> </tbody> </table>		Code	Packing	R	3k pcs./reel				
Code	@ +25°C																								
2	± 20 ppm																								
1	± 10 ppm																								
Code	Temp. Range																								
I	-40°C to +85°C																								
G	-40°C to +105°C																								
Code	Packing																								
R	3k pcs./reel																								

Notes:

**Not all performance combinations and frequencies may be available.
Contact your local CTS Representative or CTS Customer Service for availability.**

This product is specified for use only in standard commercial applications. Supplier disclaims all express and implied warranties and liability in connection with any use of this product in any non-commercial applications or in any application that may expose the product to conditions that are outside of the tolerances provided in its specification.

Electrical Specifications

Operating Conditions

PARAMETER	SYMBOL	CONDITIONS	MIN	TYP	MAX	UNIT
Operating Temperature	T _A	-	-40	+25	+85	°C
			-40		+105	
Turnover Temperature	T _M	-	+20	+25	+30	°C
Storage Temperature	T _{STG}	-	-55	-	+125	°C

Frequency Stability

PARAMETER	SYMBOL	CONDITIONS	MIN	TYP	MAX	UNIT
Frequency	f ₀	-		32.7680		kHz
Frequency Tolerance [Note 1]	Δf/f ₀	Standard @ +25°C	-20	-	20	ppm
Parabolic Coefficient	β	See Figure 1		-0.034 ±0.010		ppm/°C ²
Aging	Δf/f ₀	First Year @ +25°C	-3	-	3	ppm

Crystal Parameters

PARAMETER	SYMBOL	CONDITIONS	MIN	TYP	MAX	UNIT
Operating Mode	-	-		Flexural Mode [Tuning Fork]		-
Load Capacitance [Note 1]	C _L	Standard	-	12.5	-	pF
Shunt Capacitance	C ₀	-	-	1.3	-	pF
Motional Capacitance	C ₁	-	-	6.5	-	fF
Series Resistance	R ₁	-	-	-	90	kΩ
Drive Level	DL	-	-	0.1	0.5	μW
Insulation Resistance	R _i	+100Vdc ±15Vdc	500	-	-	MΩ

1.] See Ordering Information for available options.

Figure 1

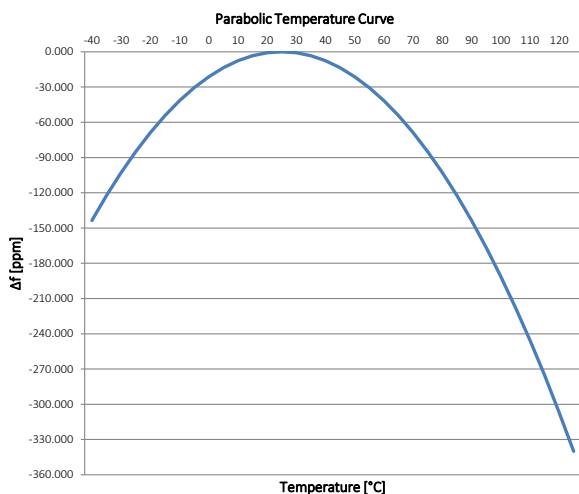

Frequency Stability [Δf] at a given temperature,

$$\Delta f = \beta [T_A - T_M]^2$$

β = Parabolic Coefficient
T_A = Ambient Temperature
T_M = Turnover Temperature

Ex. Find frequency stability at T_A = +60°C
 $\Delta f = -0.034[60-25]^2$
 $\Delta f = -0.034[35]^2$
 $\Delta f = -41.65\text{ppm}$

Mechanical Specifications

Package Drawing

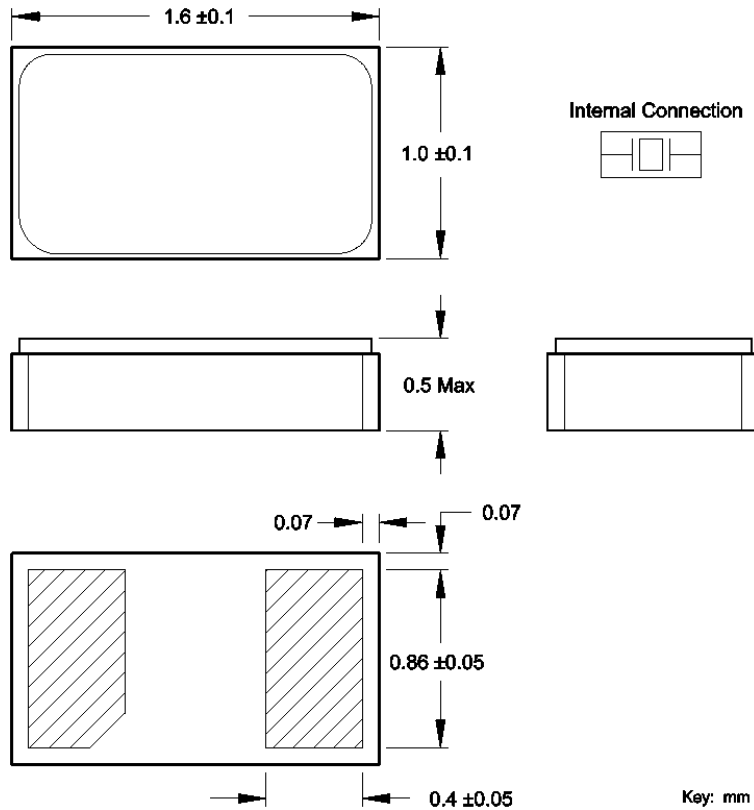

Marking Information

Refer to document 016-0071-0, TF Marking Guide, for marking format by product family.

Recommended Pad Layout

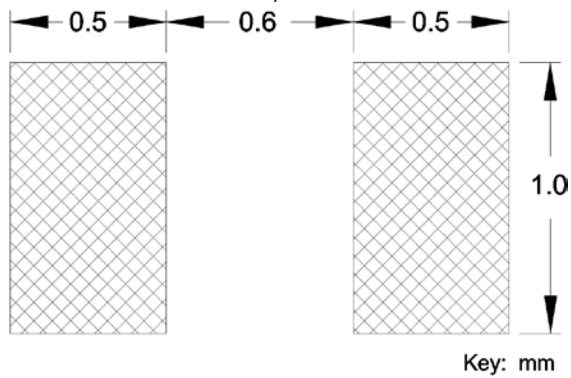

Notes

1. JEDEC termination code (e4). Barrier-plating is nickel [Ni] with gold [Au] flash plate.
2. Reflow conditions per JEDEC J-STD-020; +260°C maximum, 20 seconds.
3. MSL = 1.

Packaging - Tape and Reel

Tape Drawing

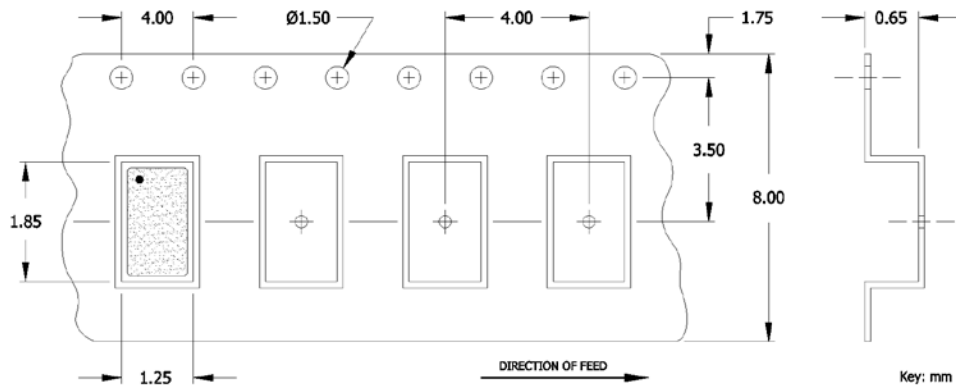

Reel Drawing

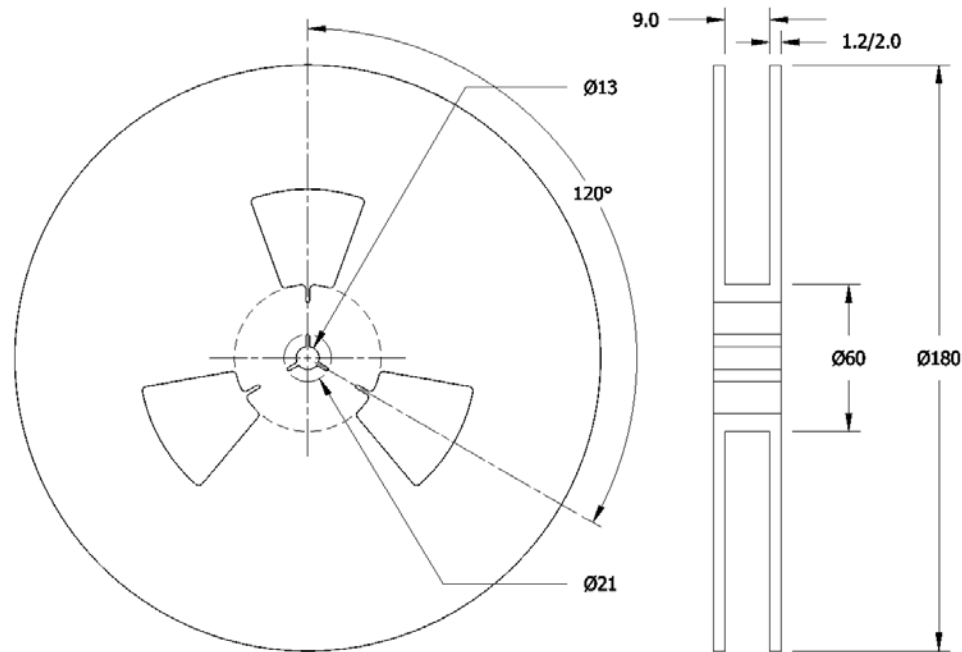

Notes

1. Device quantity is 3k pieces maximum per 180mm reel.
2. Complete CTS part number, frequency value, date code and manufacturing site code information must appear on reel and carton labels.